



Evaluation Device Type 652



- Evaluation: 2 x Type 640, 664 or He100
- Display: Vibration velocity ('vibration') in mm/s rms
- Relays:
 - Pre-alarm (Limit 1),
 - Main alarm (Limit 2),
 - OK



Evaluation Device

Type 652

Version: 09/02/2018

Attention!
Before start-up procedure, the instruction manual must be read
and understood!

All rights, including translation, reserved. Subject to changes.

1 Instruction Manual Scope

The present instruction manual is applicable for the Type 652 evaluation device.

2 The Type 652 Evaluation Device

The Type 652 evaluation device is used for detection and monitoring of the output current (4...20 mA) of one or two Type 640, 664 or HE100 vibration monitors. The evaluation device is contained in a 20-pole DIN-rail housing. It can be mounted on the wall either using a top hat rail or directly.

Basic Functions:

- Display of the current true RMS value of the vibration velocity ('vibration')
- Free adjustment of two limit values and delay times for the vibration velocity
- Cable breakage control for the sensor cable
- Voltage supply monitoring
- All warnings and alarms via relay contacts
- The evaluation device acts as the power supply for the vibration monitors

3 Intended Use

The Type 652 evaluation device may be used exclusively to detect and evaluate the output current of Type 640, 664 or HE100 vibration monitors. Operation is valid exclusively within specifications mentioned in this instruction manual.

Main areas of application: vibration monitoring on industrial fans, ventilators, blowers, electric motors, pumps, centrifuges, separators, generators, turbines, and similar oscillatory mechanical equipment, where a specific vibration value must not be exceeded.



Evaluation device and connected vibration monitors necessarily have to have identical measuring ranges! Otherwise, incorrect evaluations will happen and false alarms will be activated!

In this manual, the terms 'Sensor' and 'Monitor' have the same meaning.

4 Display and Menu Structure Type 652

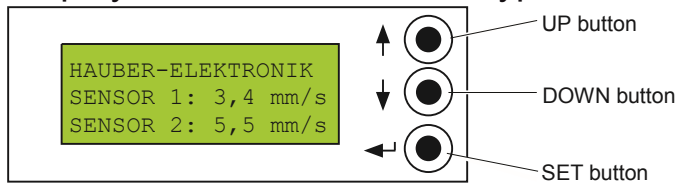

Display: start menu – 'Actual Values'

Selecting and Setting the Menus

- Press the SET button to go to the next menu.
- Press the UP or DOWN button to set the value.
- After that, press the SET button to return to the start menu.
- Each change to a different menu saves the previously set value. It remains saved even when the power supply is switched off. The display jumps back to the start menu 30 seconds after the last press of a button.
- The display jumps back to the start menu 30 seconds after the last press of a button.

Menu structure

	Description	Display	
Menu 0	Start menu: display of actual values of the vibration velocity	Hauber-Elektronik SENSOR 1: [Value] mm/s SENSOR 2: [Value] mm/s	
Menu 1	Setting number of connected sensors	NUMBER OF SENSORS [Number (1..2)]	
Menu 2	Setting delay time for START-UP	START-UP DELAY [Value (0 ... 300 s)]	
Menu 3	Sensor 1 Setting Limit Value 1 for the vibration velocity of Sensor 1	SENSOR 1 Limit Value 1 [Value in mm/s]	
Menu 4		SENSOR 1 Delay Time 1 [Value (0...60 s)]	
Menu 5		SENSOR 1 Limit Value 2 [Value in mm/s]	
Menu 6		SENSOR 1 Delay Time 2 [Value (0...60 s)]	
Menu 7		Sensor 2 Setting Limit Value 1 for the vibration velocity of Sensor 2	SENSOR 2 Limit Value 1 [Value in mm/s]
Menu 8			SENSOR 2 Delay Time 1 [Value (0...60 s)]

Menu 9	Setting Limit Value 2 for the vibration velocity of Sensor 2	SENSOR 2 Limit Value 2 [Value in mm/s]
Menu 10	Setting Delay Time 2 for Limit Value 2	SENSOR 2 Delay Time 2 [Value (0...60 s)]

5 Function

For the connected monitors, the function and operation are identical.

Limit Value 1 and Delay Time 1 have the same behaviour as Limit Value 2 and Delay Time 2.

Monitor 1 with Limit Values 1 and 2 and the Delay Times 1 and 2 are chosen here as a functional explanation:

Normal Operation and ALARM 1

Input signal	Display	Relays	Condition
> 4 mA and < Limit Value 1	Actual Value	OK relay energised SENSOR1/A relay energised	Normal operation
> Limit Value 1: Delay Time 1 starts	Actual Value and >LIMIT VALUE 1 flash alternately	OK relay energised SENSOR1/A relay energised	Normal operation
> Limit Value 1: Delay Time 1 expired	Actual Value and ALARM 1 flash alternately	OK relay energised SENSOR1/A relay drops	ALARM 1
again < Limit Value 1	Actual Value	OK relay energised SENSOR1/A relay energised	Automatic reset, Normal operation

- If Limit Value 2 is exceeded and Delay Time 2 expires, the 'Actual Value' and ALARM 2 flash alternately. SENSOR1/A relay stays dropped and the SENSOR1/B relay drops.

Important: Limit Value 2 always has to be set higher than Limit Value 1 because Limit Value 2 has priority on the display (>LIMIT VALUE and ALARM). The switching behaviour of the relays is not affected by that.

Cable Break and Power Failure

Input Signal	Display	Relays	Condition
< 3.5 mA	Actual Value and ERROR flash alternately	OK relay drops	Cable break
-	-	OK relay drops All SENSOR relays drop	Power failure

Important: In case of a power failure, all relays drop.

- Display of the device SOFTWARE version:
Simultaneously pressing the UP and DOWN button for 2 seconds.

6 Electrical Data

Input signal:	2 x	current signal (4...20 mA)
Output signal:	• 5 x relay • 2 x (looped- supply for Type 640, 664 +24 V	contact current output, output sensor 1, output sensor 2 through input signals) • Power or He100: DC
Limit values:		Between 4...20 mA, settings stepwise, hysteresis 2%
Measuring range:	Has connected vibration	to be identical to the measuring range of the monitors!
Delay times:		Between 0...60 s, settings stepwise
Relay contacts:		Changeover Switching voltage max. 250 V AC Switching power max. 60 W, 125 VA
Voltage supply:	230 V	AC, optional 115 V AC or 24 V DC
Power consumption:	ca.	5 VA
Working temperature		range: 0°C...+70°C
Display:		4-line LC display with backlighting

7 Mechanical Data

Housing:	Plastic, grey 20-pole DIN-rail On-wall W x D x H: 100 x	housing mounting possible 75 x 115 mm Weight: ca. 500 g
Protection class:	IP 20	
Operating buttons:	UP, DOWN, SET	

8 Connections

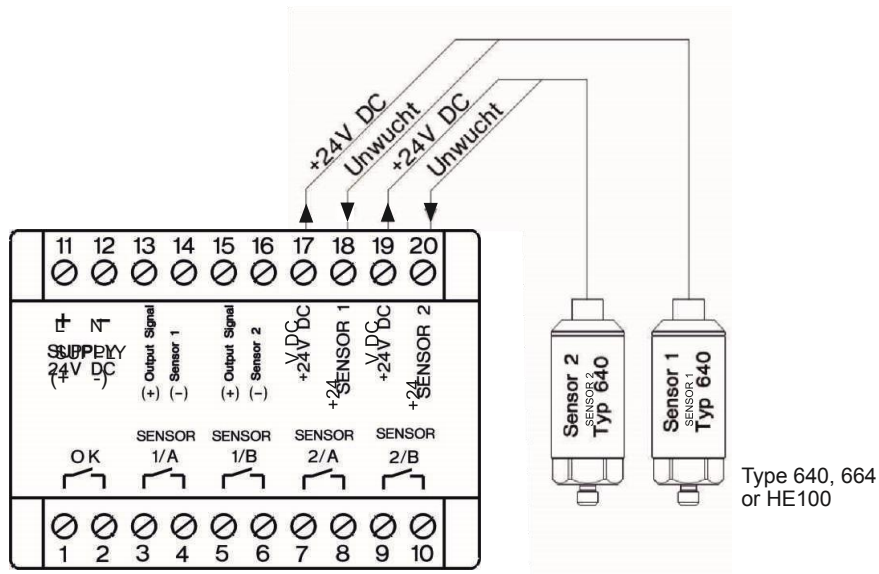

9 Housing Dimensions

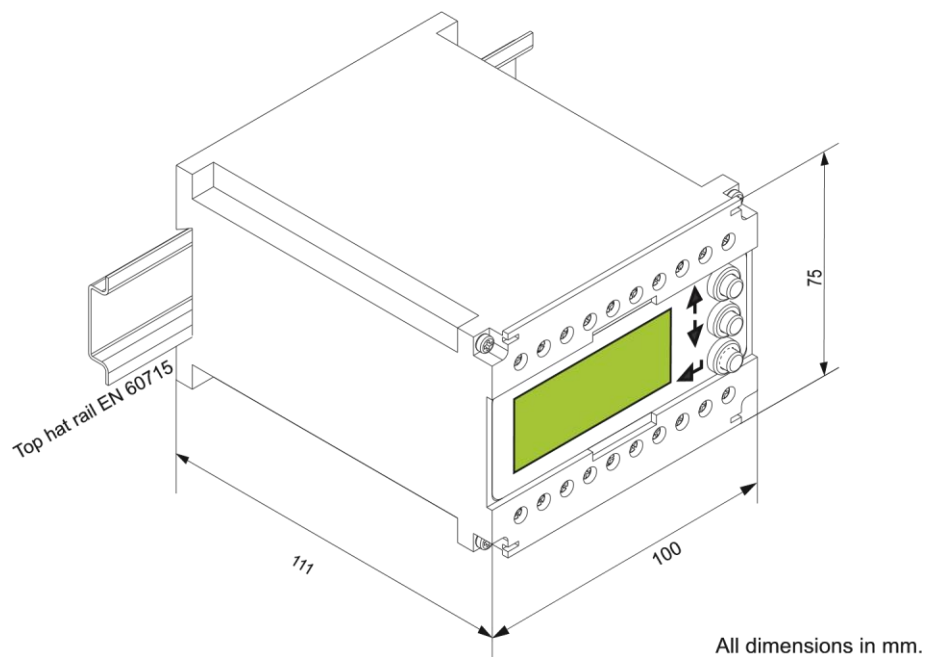

10 Mounting Options

- Top hat rail mounting: See picture above.
- On-wall mounting (via two screws): See picture below.

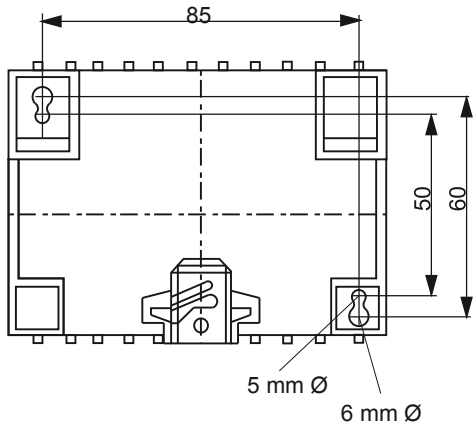

Hole distances for on-wall mounting