

Evaluation Device Type 650

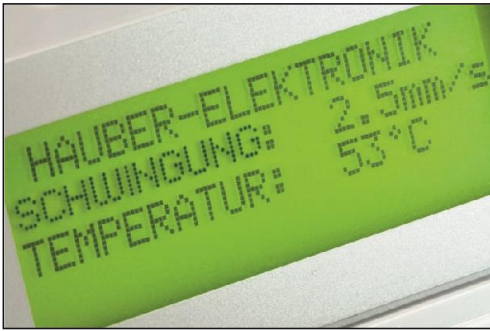

- Evaluation: Type 648 or Type HE101
- Display: Vibration velocity ('vibration') in mm/s rms, Temperature in °C
- Relays:
 - Pre-alarm (Limit 1),
 - Main alarm (Limit 2),
 - OK



Evaluation Device

Type 650

Version: 09/02/2018

Attention!
Before start-up procedure, the instruction manual must be read
and understood!

All rights, including translation, reserved.
Subject to changes.

1 Instruction Manual Scope

The present instruction manual is applicable for the Type 650 evaluation device.

2 The Type 650 Evaluation Device

The Type 650 evaluation device is used for the detection and monitoring of output currents (4...20 mA) of the Type 648 or Type HE101 vibration monitor.

The evaluation device is contained in a 20-pole DIN-rail housing.

It can be mounted on the wall either using a top hat rail or directly.

Basic Functions:

- Display of the current true RMS value of the vibration velocity ('vibration') and of the current temperature value
- Free adjustment of two limit values and delay times for vibration velocity and temperature
- Cable breakage control for the sensor cable
- Cable breakage control for the sensor cable
- Warnings and alarms are issued via relay contacts
- The evaluation device acts as the power supply for the vibration monitor.

3 Intended Use

The Type 650 evaluation device exclusively serves for the detection and evaluation of the output current of the Type 648 or Type HE101 vibration monitors.

Operation is valid exclusively within specifications mentioned in this instruction manual.

Main areas of application: vibration monitoring on industrial fans, ventilators, blowers, electric motors, pumps, centrifuges, separators, generators, turbines, and similar oscillatory mechanical equipment, where a specific vibration value and a specific temperature must not be exceeded.



The evaluation device and connected vibration monitor have to have identical measuring ranges! Otherwise, incorrect evaluations will happen and false alarms will be activated!



4 Display and Menu Structure Type 650

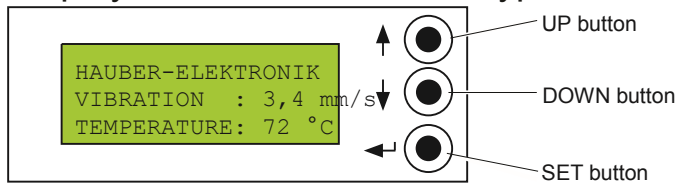

Display: start menu – 'Actual Values'

Selecting and Setting the Menus

- Press the SET button to go to the next menu.
- Press the UP or DOWN button to set the value.
- After that, press the SET button to return to the start menu.
- Each change to a different menu saves the previously set value.
The values remain saved even when the power supply is switched off.
- The display jumps back to the start menu 30 seconds after the last press of a button.

Menu Structure

	Description	Display	
Menu 0	Start menu – display of actual values of vibration velocity in mm/s, rms and of temperature in °C	Hauber-Elektronik VIBRATION: [Value] mm/s TEMPERATURE: [Value] °C	
Menu 1	Setting delay time for START-UP (starts when the power supply of the Type 650 is switched on, to avoid false alarms during start-up of the machine.)	START-UP DELAY [Value (0...300 s)]	
Menu 2	Vibration Velocity	Setting Limit Value 1 for the vibration velocity	VIBRATION Limit Value 1 [Value in mm/s]
Menu 3		Setting Delay Time 1 for the Limit Value 1	VIBRATION Delay Time 1 [Value (0...60 s)]
Menu 4		Setting Limit Value 2 for the vibration velocity	VIBRATION Limit Value 1 [Value in mm/s]
Menu 5		Setting Delay Time 2 for the Limit Value 2	VIBRATION Delay Time 2 [Value (0...60 s)]
Menu 6	Temperature	Setting Limit Value 1 for the temperature	TEMPERATURE Limit Value 1 [Value in °C]
Menu 7		Setting Delay Time 1 for the Limit Value 1	TEMPERATURE Delay Time 1 [Value (0...60 s)]
Menu 8		Setting Limit Value 2 for the temperature	TEMPERATURE Limit Value 2 [Value in °C]
Menu 9		Setting Delay Time 2 for the Limit Value 2	TEMPERATURE Delay Time 2 [Value (0...60 s)]

5 Function

For the connected monitor, the function and operation are identical for temperature and vibration velocity. Limit Value 1 and Delay Time 1 have the same behaviour as Limit Value 2 and Delay Time 2. The vibration velocity with Limit Values 1 and 2 and Delay Times 1 and 2 serve here as a functional example:

Normal Operation and ALARM 1

Input signal	Display	Relays	Condition
> 4 mA < Limit Value 1	'Actual Value'	OK relay and VIBRATION1 relay energised	Normal operation
> Limit Value 1: Delay Time 1 starts	'Actual Value' and '>LIMIT VALUE 1' flash alternately	OK relay and VIBRATION1 relay energised	Normal operation
> Limit Value 1: Delay Time 1 expired	'Actual Value' and 'ALARM 1' flash alternately	OK relay energised VIBRATION1 relay drops	ALARM 1
again < Limit Value 1	'Actual Value'	OK relay and VIBRATION1 relay energised	Automatic reset, Normal operation

- If Limit Value 2 is exceeded and Delay Time 2 expires, the 'Actual Value' and ALARM 2 flash alternately. VIBRATION1 relay stays dropped and the VIBRATION2 relay drops.

Important: Limit Value 2 always has to be set higher than Limit Value 1 because Limit Value 2 has priority on the display (>LIMIT VALUE and ALARM). The switching behaviour of the relays is not affected by that.

Cable Break and Power Failure

Input Signal	Display	Relays	Condition
< 3.5 mA	'Actual Value' and 'ERROR' flash alternately	OK relay drops	Cable break
-	-	OK relay drops and all VIBRATION relays drop	Power failure

Important: In case of a power failure, all relays drop.

- Display of the device SOFTWARE version:
Simultaneously pressing the UP and DOWN button for 2 seconds.

6 Electrical Data

Input signal:	2 x	current signal (4...20 mA)
Output signal:	• 5 x relay	contact
• 2 x current output:		output vibration, output temperature (looped-through input signals)
• Power supply for the	Type	648 or Type He101 monitor: +24 V DC
Measuring range:	Has to	be identical to Type 648 or Type HE101!
(Vibration velocity RMS/ temperature)		
Limit values:	Settings	stepwise, hysteresis 2%
Delay times:	Settings	stepwise, between 0...30 s.
Relay contacts:		Changeover Switching voltage max. 250 V AC Switching power max. 60 W, 125 VA
Voltage supply:	230 V	AC, optional 115 V AC or 24 V DC
Power consumption:	ca. 5	VA
Working temperature		range: 0°C...+70°C
Display:		4-line LC display with backlighting

7 Mechanical Data

Housing:	Plastic, grey	housing	On-wall
20-pole DIN-rail mounting possible			
W x D x H: 100 x		75 x 115 mm	
Weight:	ca. 500 g		
Protection class:	IP 20		
Operating buttons:	UP,	DOWN, SET	

8 Connections

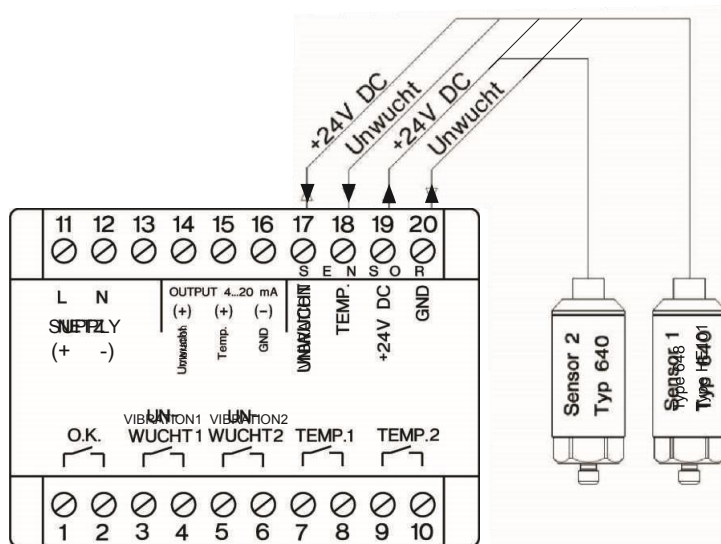

9 Housing Dimensions

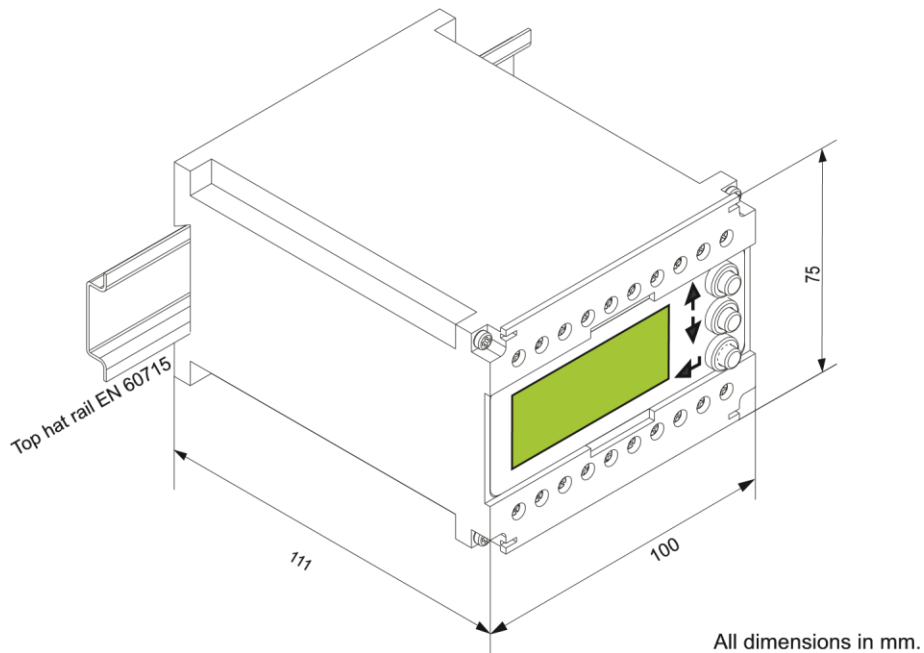

10 Mounting Options

- a. Top hat rail mounting: See picture above.
- b. On-wall mounting (via two screws): See picture below.

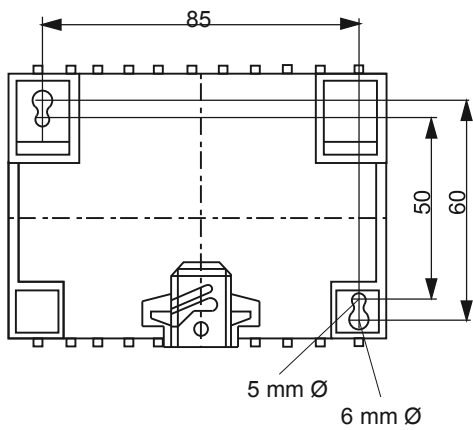

Hole distances for on-wall mounting